



Built-in driver

**Up to
3 meters**

**Customizable
software**

High-Uniformity

Easy-to-use

Water resistant



effiFLEX2-IP67

Multimode LED bar light

PART NUMBERING

STANDARD VERSION

EFFI-FLEX2-IP67	- XXXX	- ZZZ	- WW	- PP
	Optical Length [mm]	Wavelength [nm]	Window	Lens position
	60	● 365* (UV)	TR (Transparent)	P0 (90°)
	100	● 405 (UV)	SD (Semi-diffuse)	P1 (45°)
	200	● 465 (Blue)	OP (Opaline)	P2 (25°)
	300	● 525 (Green)		P3 (10°)
	... Every 100mm	● 625 (Red)		
	2900	● 850 (Infrared)		
		○ 000 (White)		

(*) The UV 365nm wavelength is a specific configuration. Refer to the corresponding annex.

AVAILABLE VERSIONS & OPTIONS

OTHER VERSIONS - Compatible with each other	
Watercooling version	EFFI-FLEX2-IP67- WTR -XXXX-ZZZ-WW-PP Allow the use of a watercooling system for thermal regulation.
Other LED densities versions L2 - Economical X2 - High uniformity	EFFI-FLEX2-IP67- L2 -XXXX-ZZZ-WW-PP 1 LED every 40mm vs 1 LED every 20mm for standard (See corresponding Annex)
	EFFI-FLEX2-IP67- X2 -XXXX-ZZZ-WW-PP 1 LED every 10mm vs 1 LED every 20mm for standard (See corresponding Annex)
OPTICAL OPTIONS	
Polarizer accessory	EFFI-FLEX2-IP67-XXXX-ZZZ-WW-PP- POL (See page 5)
Linescan film	EFFI-FLEX2-IP67-XXXX-ZZZ- TR-P3-LS (See page 5)
ELECTRONICAL OPTIONS	
Continuous boost (ELS XXX)	EFFI-FLEX2-IP67-XXXX-ZZZ-WW-PP- ELSxxx (xxx = 500 / 700 / 1000) For experts who need a power boost in continuous mode. Only available in WTR version.
Customized software	EFFI-FLEX2-IP67-XXXX-ZZZ-WW-PP- SWxxxxxx Specific reference xxxxx for each customized software.
CONNECTOR OPTIONS	
Connector position and orientation, Cables position	EFFI-FLEX2-IP67-XXXX-ZZZ-WW-PP- SCXXX/SCG

TECHNICAL SPECIFICATIONS

effiFLEX2-IP67

Illumination Mode	Overdrive, Strobe or continuous			
Wavelengths	365nm, 405nm, 465nm, 525nm, 625nm, 850nm (+/- 5nm) White (5500K ±500K) (Other wavelength upon request)			
Power Supply	24V DC (+/-10%)			
Connector(s) <i>(See wiring layout page 6)</i>	Optical length	60mm - 400mm	500mm - 1500mm	1600mm - 2900mm
	Type	M12 (A-coded) - 5 pins	M12 Power (T-coded) - 4 pins	2x M12 Power (T-coded) - 4 pins
Power Consumption <i>(See details page 6)</i>	In continuous mode	Max. 10W per 100 mm of optical length		
	In Autostrobe mode (peak)	Max. 40W per 100mm of optical length		
Built-in driver version	Multimode (3 modes: AutoStrobe with overdrive intensity / Dimmable strobe / Dimmable continuous)			
Analog Intensity Control (AIC)	The output optical power is adjustable from 20% to 100% by applying a signal from [2V-10VDC] Total voltage range [1.5V-24VDC] / Don't exceed 24V DC / Max. signal consumption: 4mA			
Autostrobe	450% Overdrive during 245 ms max then continuous at 100%			
	Max. duty cycle 30%			
	PNP trigger input: Light ON from 4.5V* to 24V / Don't exceed 24VDC / Max. signal consumption: 4mA (Option NPN for size ≥ 500mm, on PIN4: Light ON from 0V to 1V / Don't exceed 24V DC / Max. signal consumption: 4mA)			
Response time	Max. 10µs (<i>Rise time included</i>)			
Weight	Approx. 315g per 100mm of optical length			
Dimensions	54mm x 37.5mm x Length (= Optical length + 35mm) - <i>See the drawing on page 8</i>			
Material	Device body: Aluminum alloy / Window: PMMA			
Fastener	T-slot on the back for M6 T-nuts 8mm slot (2x M6 T-nuts included)			
IP rating	IP67			
Operation environment	Temperature: 0°C to 40°C - Humidity: 20 to 85%RH (with no condensation) - Altitude: Up to 2000m			
Storage environment	Temperature: -20° to 60°C - Humidity: 20 to 85%RH (with no condensation)			
Informations	Overvoltage category I - Protective class III - Pollution degree 3			
Regulations & Marking	CE - UKCA			
Environmental Standards	RoHS Directives (2011/65/EU, 2015/863/EU and China RoHS) - REACH Regulation - WEEE Regulation			
Country of Origin	France			

***Note:** The PNP threshold voltage of 4.5V may vary according to lengths and power consumption. (Please refer to the related table value in the User Manual of EFFI-Flex2-IP67)

OPTICAL SPECIFICATIONS

THREE DIFFERENT WINDOWS TO ADJUST LIGHT UNIFORMITY

Diffusers



TR : Transparent



SD : Semi-diffuse



OP : Opaline

Choose the best configuration for your use-case : More diffusion (left to right) yields greater uniformity but reduces light power.

FOUR LENS POSITIONS TO ADJUST BEAM ANGLE

With the EFFI-Flex2-IP67, users can customize the light beam angle. The default position is P2, but alternate specifications are available upon ordering: placing the lenses closer to the window narrows the light angle.

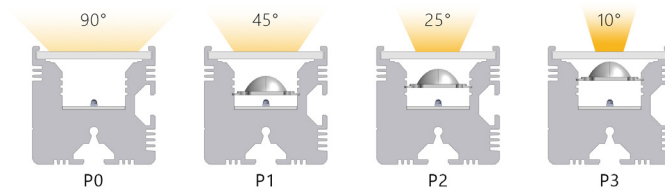

Irradiance maps

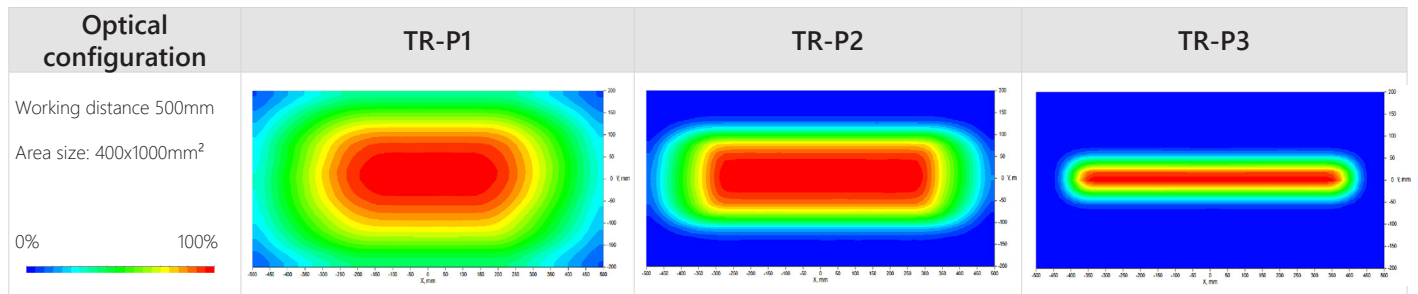

Intensity vs Working distance (WD)

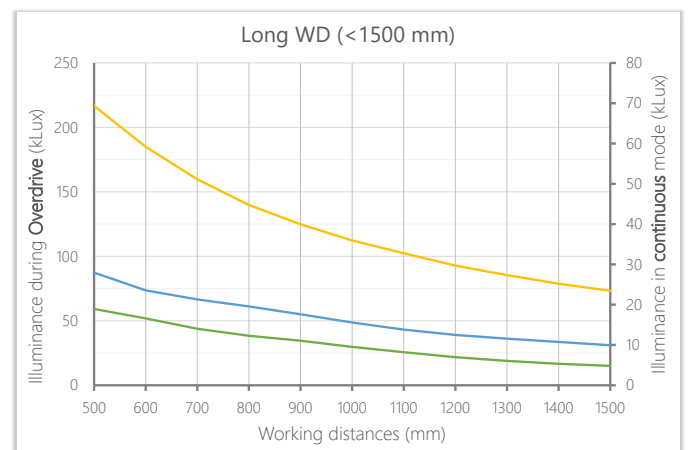
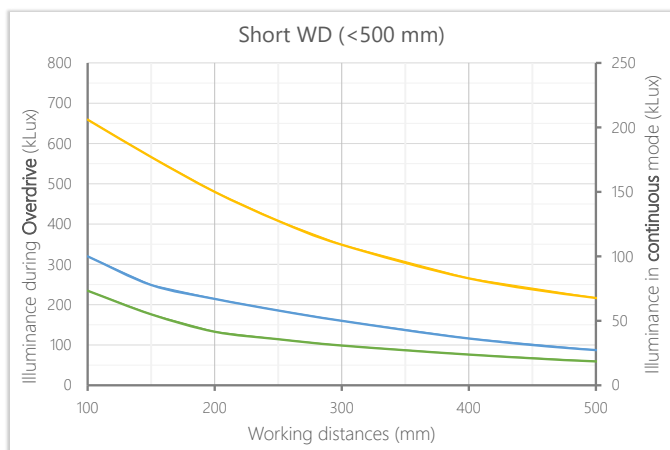

— Lens position P1 — Lens position P2 — Lens position P3

POLARIZER

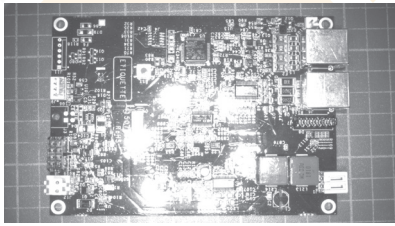

Without polarizer

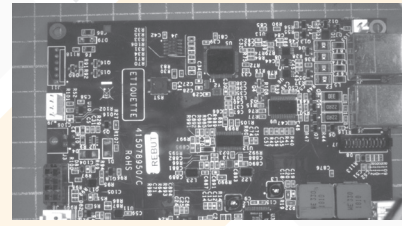

With polarizer

Using polarizers, on the Efflux light and on the camera, helps acquiring suitable images by eliminating glare issued from the workpiece .



The polarizer film is positioned just under the window on demand when ordering.

Important note: The polarization is optimal with a TR window, the use of diffuser (SD or OP) can depolarize the light.

LINESCAN CONFIGURATIONS

Linescan film (TR-P3-LS)

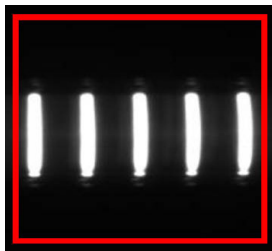

Without Linescan film

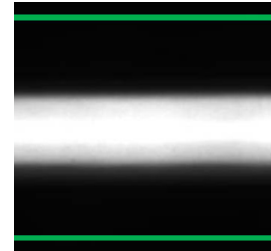

With Linescan film

With the lens in the upper position (P3) and the transparent window (TR), the linescan filter accessory transforms the EFFI-Flex2-IP67 into a uniform line light ideal for either brightfield or darkfield illumination.

ELECTRONICAL SPECIFICATIONS

OVERVIEW

The EFFI-Flex2-IP67 has been designed to have several electronic modes available in the same product. Additionally to that, engineers have developed a strong AutoStrobe mode to reach 450% light intensity.

Thus, EFFI-Flex2-IP67 can be used to have a:

- **High power strobe - Autostrobe mode:** Light intensity at 450%. Max duty cycle of 30% and max pulse duration of 245ms.
- **DIM modes :** Light intensity between 20% and 100% monitored with the AIC pin and strobe or continuous mode monitored with the trigger pin.

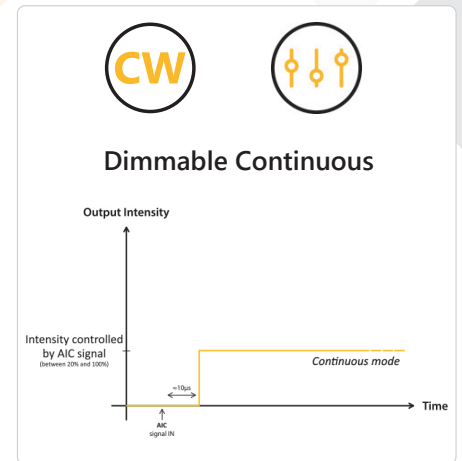
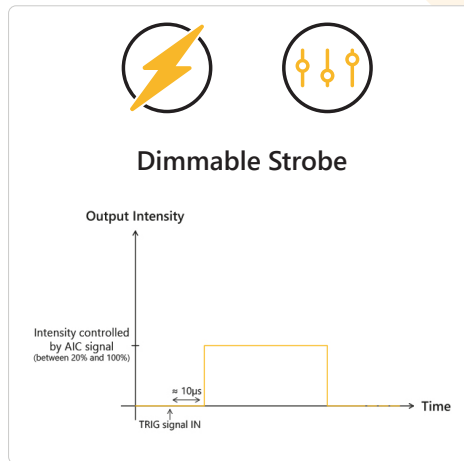
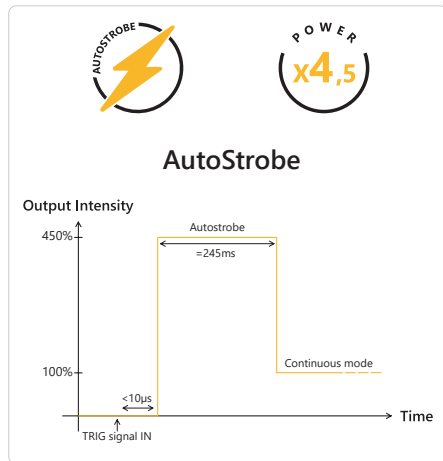

ANALOG INTENSITY CONTROL (AIC)

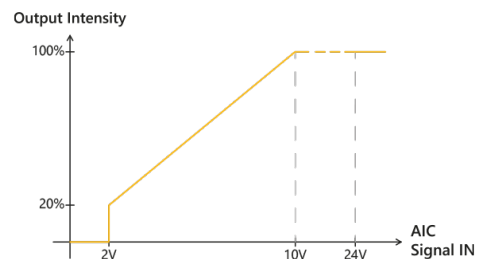

- The output intensity can be adjusted from 20% to 100% by applying a signal from [2V-10V DC].
- If $V_{AIC} = [0V-1V DC]$ or if not connected, the EFFI-Flex2-IP67 is in AutoStrobe mode by default.

POWER CONSUMPTION & CONNECTOR DEFINITION

MAX POWER CONSUMPTION (+/- 5%) (White LED - Standard software)															
Optical Length XXXX (mm)	60	100	200	300	400	500	600	700	800	900	1000	1100	1200	1300	1400
In Continuous mode	<10W	10W	15W	20W	25W	35W	40W	45W	50W	60W	65W	70W	75W	80W	90W
In AutoStrobe mode (peak)	<30W	30W	60W	95W	130W	170W	205W	240W	280W	315W	350W	390W	425W	460W	500W
Optical Length XXXX (mm)	1500	1600	1700	1800	1900	2000	2100	2200	2300	2400	2500	2600	2700	2800	2900
In Continuous mode	95W	100W	105W	115W	120W	125W	130W	140W	145W	150W	155W	160W	170W	175W	180W
In AutoStrobe mode (peak)	535W	570W	610W	645W	685W	720W	755W	790W	830W	865W	905W	940W	975W	1010W	1050W

M12 - 5 pins

M12P - 4 pins

2x M12P - 4 pins

Note: These values are maximum values. The consumption may vary according to the wavelength and the software.

WIRING LAYOUT

Depending on the size, the light comes with different connectors (refer to the table above).

M12 (A-coded)- 5 pins

male connector

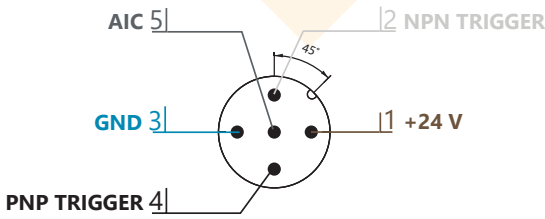

M12 Power (T-coded) - 4 pins

male connector

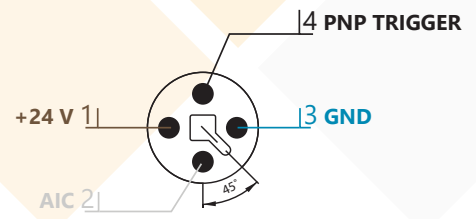

Notes:

- The EFFI-FLEX2-IP67 requires 24V DC input power.
- PNP trigger pin (or NPN) needs to be connected either to a trigger signal for AutoStrobe and Strobe mode or to a continuous signal for Continuous mode.
- AIC pin can stay unplugged for Autostrobe mode, or tied to +24V for continuous mode at maximum intensity.
- (*) For light requiring M12P connector, the NPN trigger is optional. With the NPN option, the PNP trigger input is replaced by the NPN trigger input.

LAYOUT EXAMPLE (PNP)

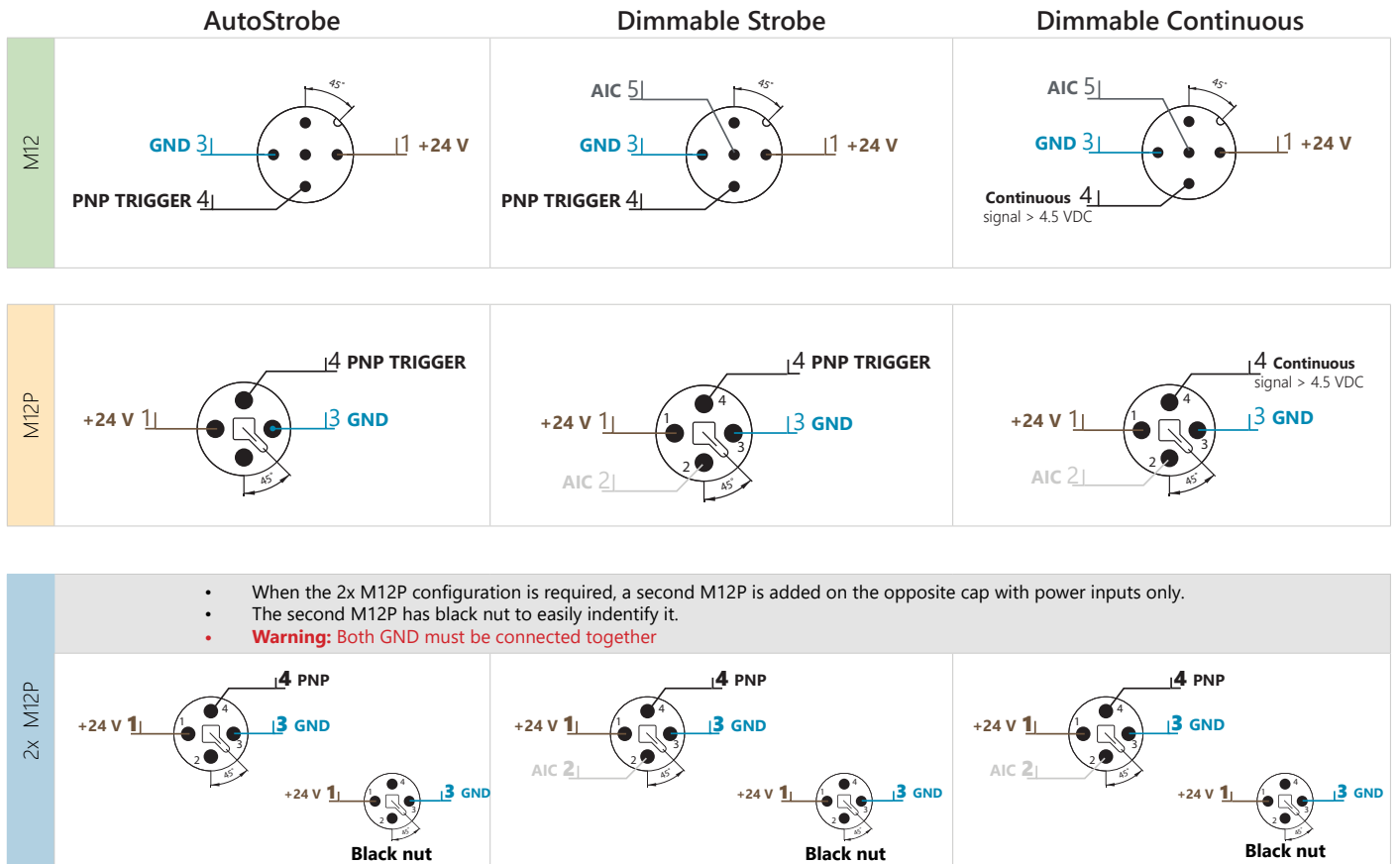

CONTINUOUS POWER BOOST (ONLY WITH WTR VERSION)

With the ELS500, ELS700 and ELS1000 options the EFFI-FLEX2-IP67 light power can be improved for continuous use. These configurations only work with the WTR version as extra heat is produced. As this is an expert configuration, get in touch with Efflux before implementing it.

MECHANICAL SPECIFICATIONS

DIMENSIONS OF EFFI-FLEX2-IP67 - M12 & M12P (in mm)

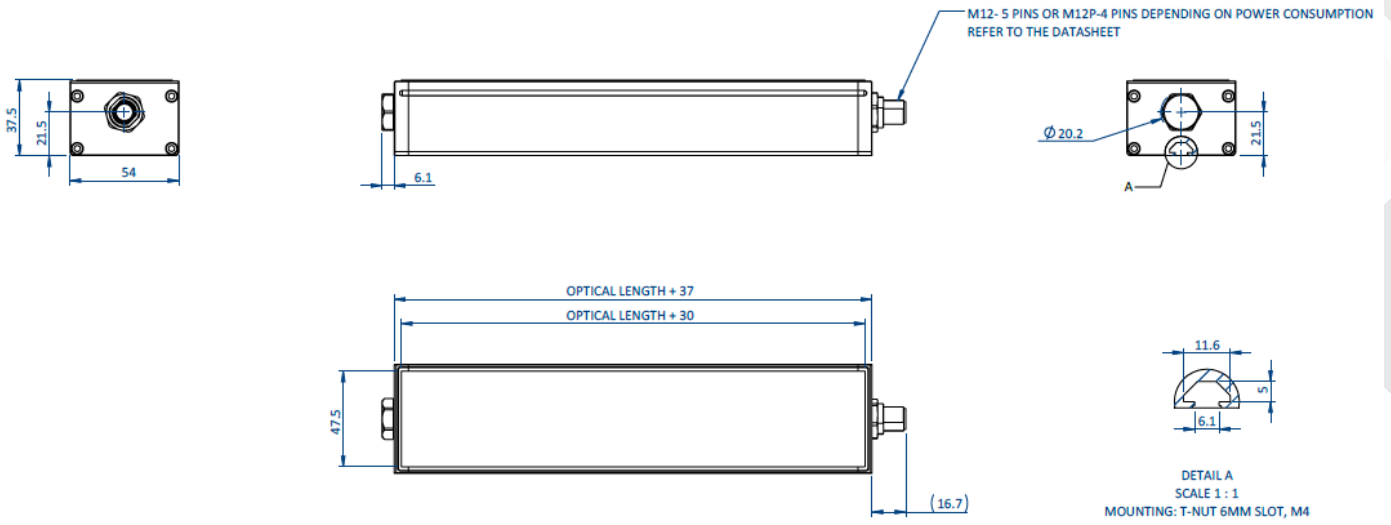

DIMENSIONS OF EFFI-FLEX2-IP67 - 2M12P (in mm)

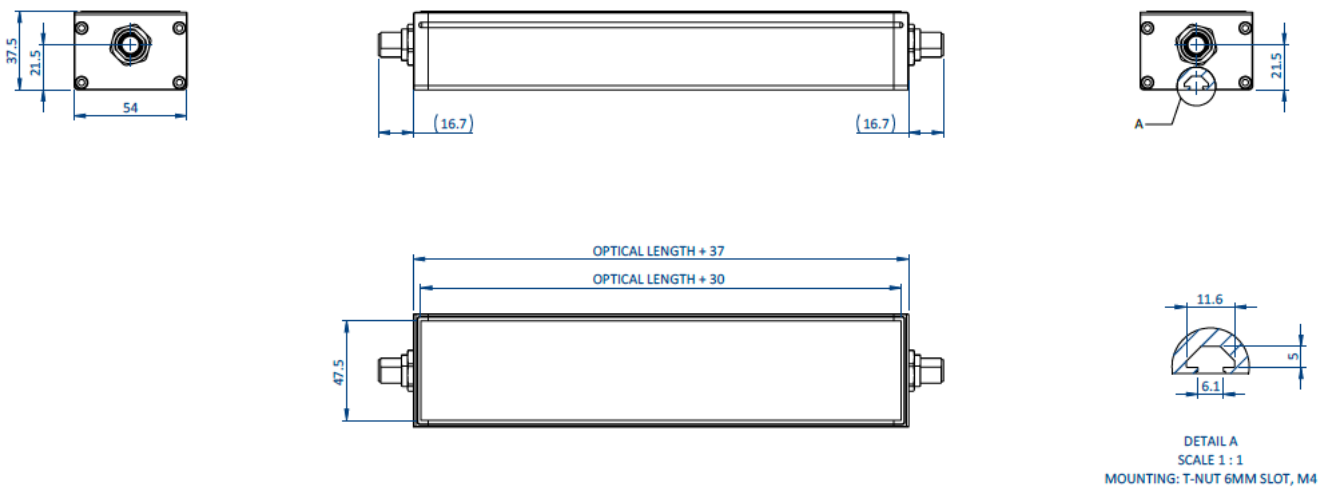

DIMENSIONS OF EFFI-FLEX2-IP67-WTR - M12 & M12P (in mm)

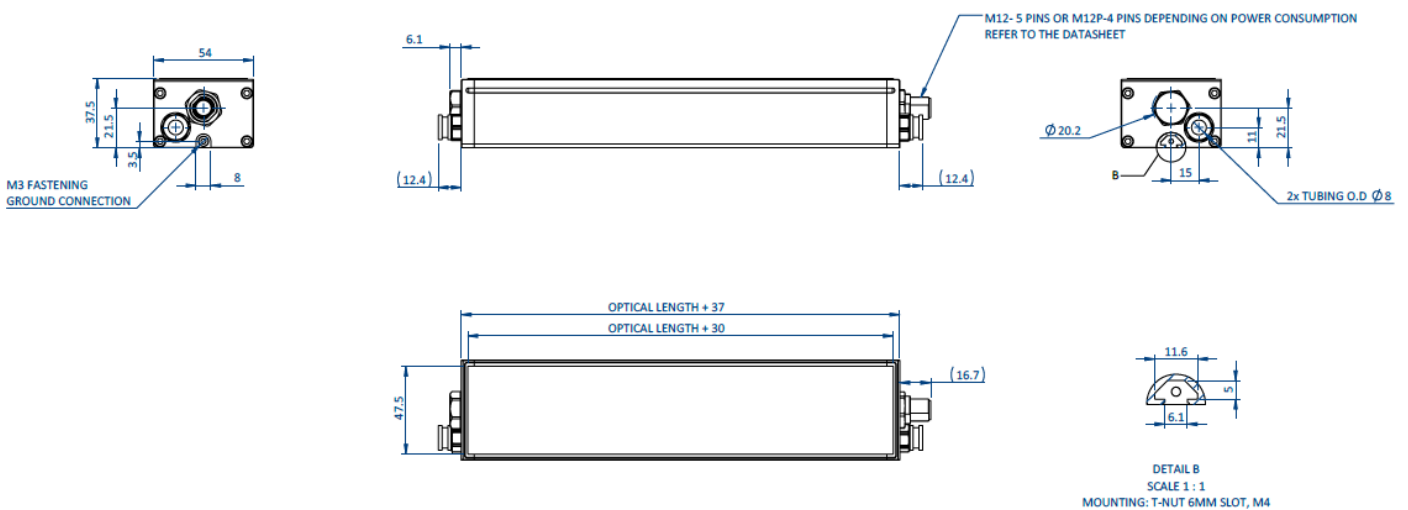

DIMENSIONS OF EFFI-FLEX2-IP67-WTR - 2M12P (in mm)

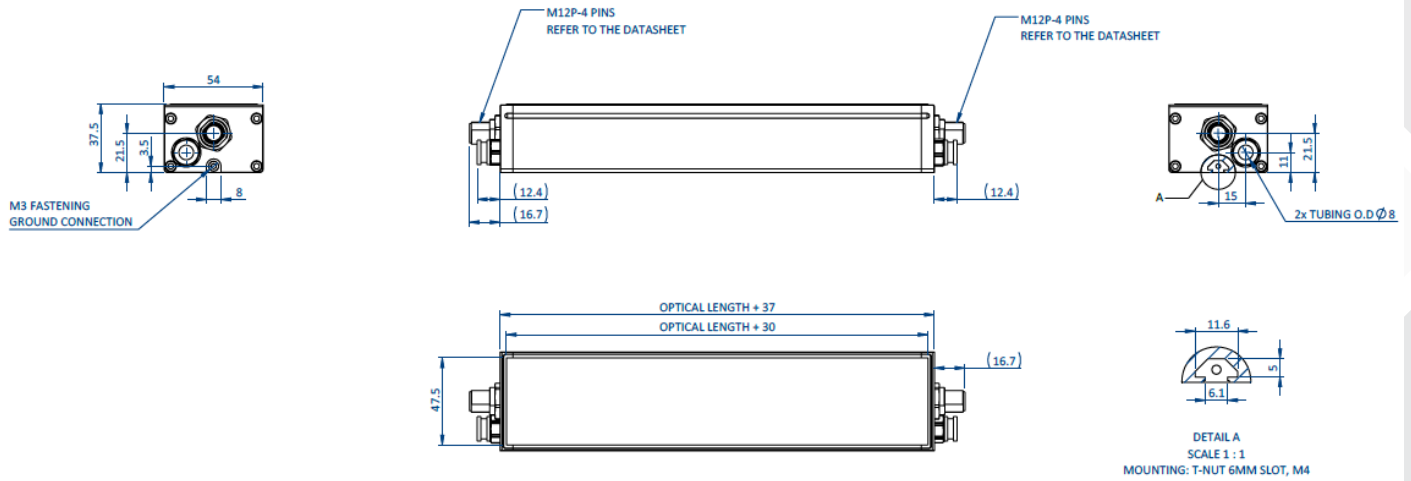

DIMENSIONS OF EFFI-FLEX2-IP67-...CYL - M12 & M12P (in mm)

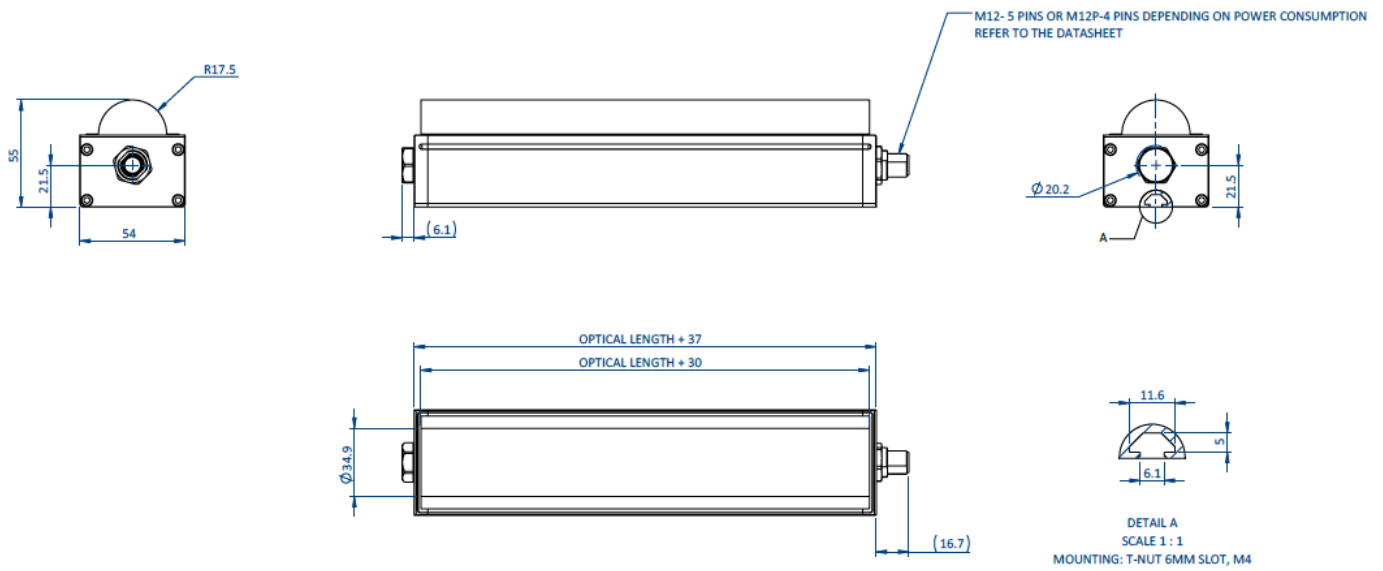

DIMENSIONS OF EFFI-FLEX2-IP67-...CYL - 2M12P (in mm)

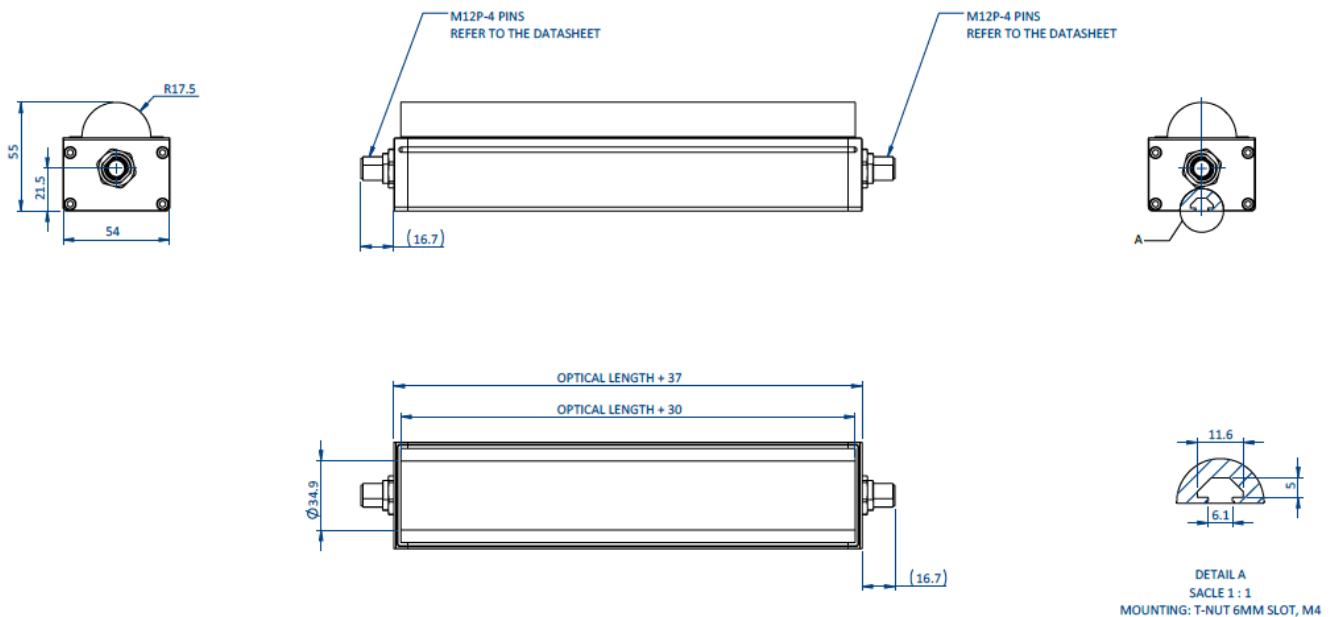

DIMENSIONS OF EFFI-FLEX2-IP67-WTR-...CYL - M12 & M12P (in mm)

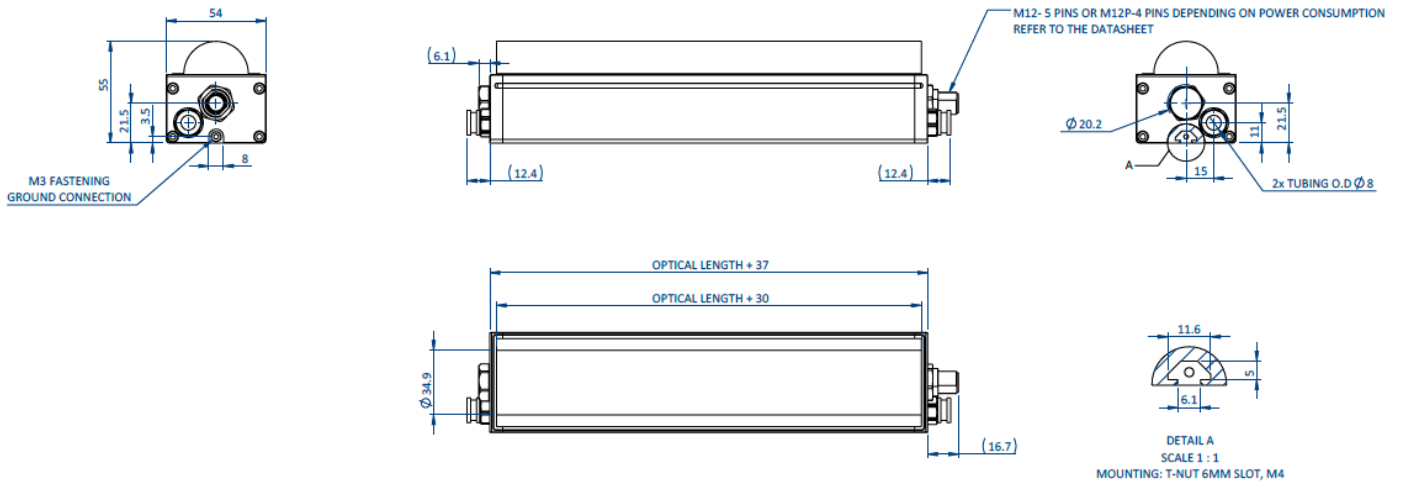

DIMENSIONS OF EFFI-FLEX2-IP67-WTR-...CYL - 2M12P (in mm)

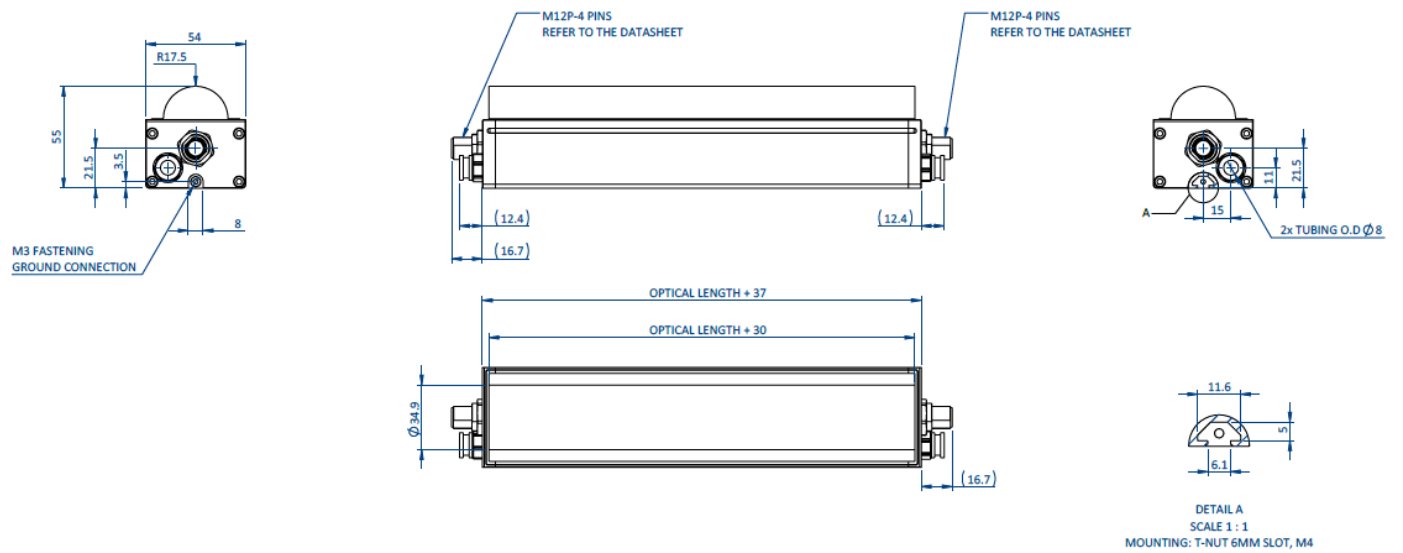

ACCESSORIES

Please refer to the specific documentation for additional information on the accessories of the EFFI-Flex2-IP67.



Fasteners

T-Nut Kit: EFFV-BOLT-0011
Pivot joint Kit: EFFM-1-0002



Extension cables

2meters: EFFC-CAB-M12-FM-5-DD-L2
5meters: EFFC-CAB-M12-FM-5-DD-L5
10meters: EFFC-CAB-M12-FM-5-DD-L10



Camera Filters

EFFO-FLR-...

OTHER CUSTOMIZATION

Please ask your sales contact for a custom device.

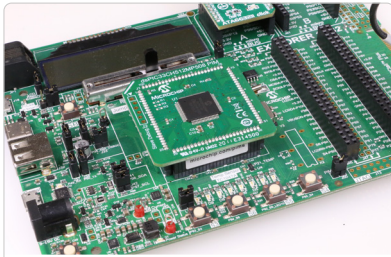

Custom software

CONTACT INFORMATION

Please refer to the specific documentation (datasheet, user manual and drawing) for complementary information. Contents of this document are based on information available as of October-2024 and may be changed without prior notice.



EFFILUX
1, Rue de Terre Neuve
Mini Parc du Verger - Bâtiment E
91940 Les Ulis - FRANCE

Tel: +33 9 72 38 17 80
Fax: +33 9 72 11 21 69
Mail: sales@effilux.fr

Copyright 2022 Effilux - All rights Reserved

effiFLEX2-IP67 UV365

Multimode Flexible UV LED bar light

PART-NUMBERING

EFFI-FLEX2-IP67 - XXXX	- ZZZ	- WW	- PP
Optical Length [mm]	Wavelength [nm]	Window	Lens position
60	● 365 (UV)	TR (Transparent special UV)	P0 (90°)
100			
... All 100mm			
2900			

Notes:

- The EFFI-Flex2-IP67 UV365 comes with one possible configuration: transparent window and lens position at P0 (90°) (i.e. no lenses)
- The transparent window for this reference is a special made transparent window for UV365. The standard transparent window of EFFI-Flex2-IP67 is not compatible with this configuration.
- Linescan film and standard polarizer are not compatible with UV365.
- For maximum performances, please use a cable with **no longer than 5m**. Otherwise, the overdrive performances may be impacted.

AVAILABLE VERSIONS AND OPTIONS

OPTICS	
Pure UV option	EFFI-FLEX2-IP67-XXXX-365-TR-P0- PUV (See details next page)
Cylindrical lens	EFFI-FLEX2-IP67-XXXX-365- TR-P0-CYL (See details next page)
L2: Economical version	EFFI-FLEX2-IP67- L2 -XXXX-365-TR-P0 1 LED every 40mm vs 1 LED every 20mm for standard (See corresponding Annex)

ELECTRONICAL MODES

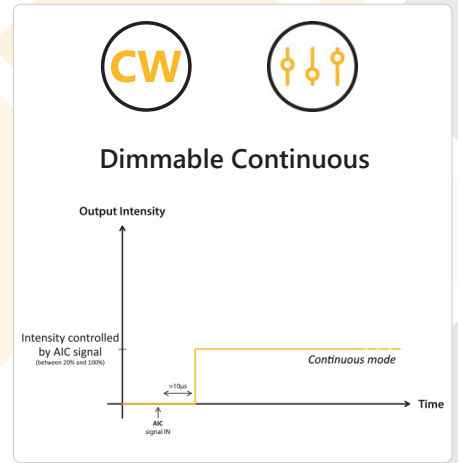
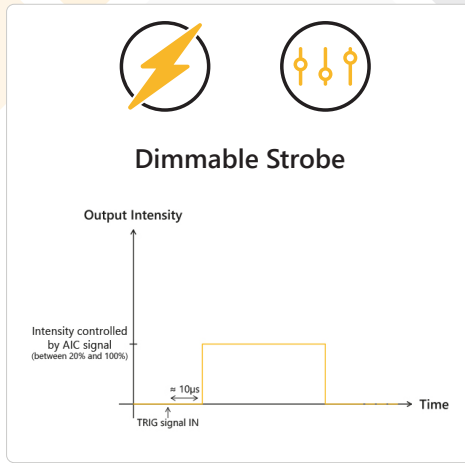
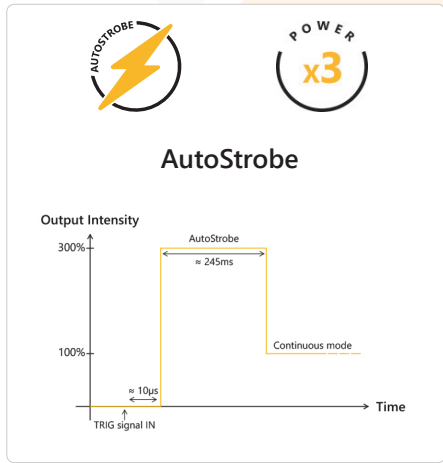

Note: Compared to the standard version the autostrobe overdrive mode has been capped at 300% of the continuous level.

PURE UV OPTION



Used with the EFFI-Flex2-IP67 UV 365, the Pure UV technology is an innovative system that drastically improves the fluorescence effect while concurrently removing glare and improving contrast.

Note: The Pure UV light must be used along with a UV Cut filter on the camera.

CYLINDRICAL LENS

The additional Cylindrical lens (CYL) allows to focus even more the light into a very bright line.

Illuminance vs Working distance (WD)

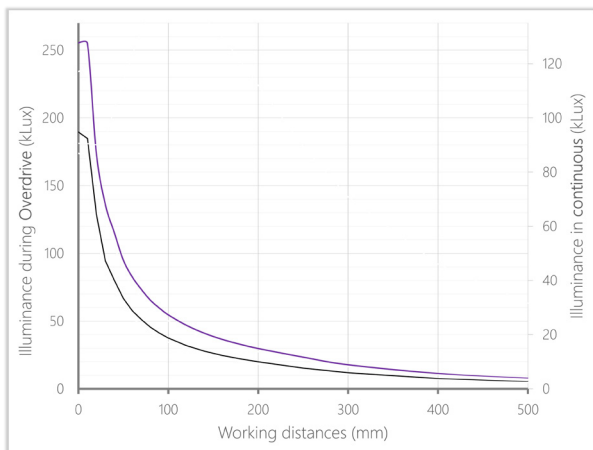

— EFFI-Flex2 UV365 — EFFI-Flex2 UV365 PUV

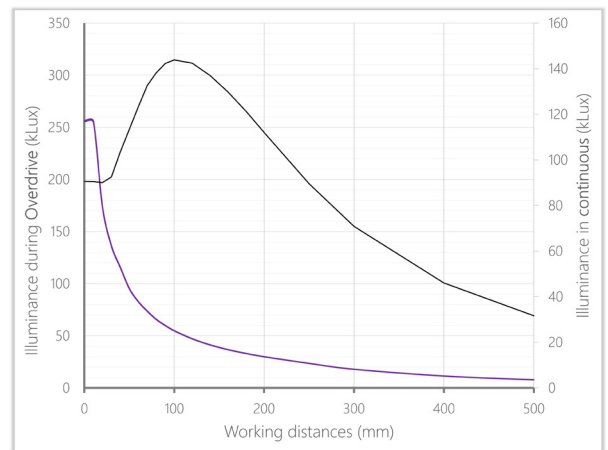

— EFFI-Flex2 UV365 — EFFI-Flex2 UV365 CYL

Note: The measurements have been made with a 300mm UV light, transparent window and lens position 0: EFFI-FLEX2-300-365-TR-P0.

ANNEX 2 - OTHER LED DENSITIES

The standard LED density for the EFFI-Flex2-IP67 is one LED every 20mm. However, we propose two other LED densities:

- L2 - Economical version : We put one LED every two slots (every 40mm).
- X2 - High light uniformity : We put one LED in between each standard LED (every 10mm).

Those modifications change the power consumptions and the light uniformity. For these references refer to the datas below.

POWER CONSUMPTION & CONNECTOR DEFINITION

L2 version

MAX POWER CONSUMPTION (+/- 5%) (White LED - Standard software)														
Optical Length XXXX (mm)	200	400	600	800	1000	1200	1400	1600	1800	2000	2200	2400	2600	2800
In Continuous mode	10W	15W	20W	25W	35W	40W	45W	50W	60W	65W	70W	75W	80W	90W
In AutoStrobe mode (peak)	30W	60W	95W	130W	170W	205W	240W	280W	315W	350W	390W	425W	460W	500W

M12 - 5 pins

M12P - 4 pins

2x M12P - 4 pins

X2 version (Same as standard)

MAX POWER CONSUMPTION (+/- 5%) (White LED - Standard software)														
Optical Length XXXX (mm)	100	200	300	400	500	600	700	800	900	1000	1100	1200	1300	1400
In Continuous mode	10W	15W	20W	25W	35W	40W	45W	50W	60W	65W	70W	75W	80W	90W
In AutoStrobe mode (peak)	30W	60W	95W	130W	170W	205W	240W	280W	315W	350W	390W	425W	460W	500W

Optical Length XXXX (mm)	1500	1600	1700	1800	1900	2000	2100	2200	2300	2400	2500	2600	2700	2800	2900
In Continuous mode	95W	100W	105W	115W	120W	125W	130W	140W	145W	150W	155W	160W	170W	175W	180W
In AutoStrobe mode (peak)	535W	570W	610W	645W	685W	720W	755W	790W	830W	865W	905W	940W	975W	1010W	1050W

M12 - 5 pins

M12P - 4 pins

2x M12P - 4 pins

Note: These values are maximum values. The consumption may vary according to the wavelength and the software.

ANNEX 3 - CONNECTORS & CABLE OPTIONS

SIDE CONNECTOR - M12 & M12P

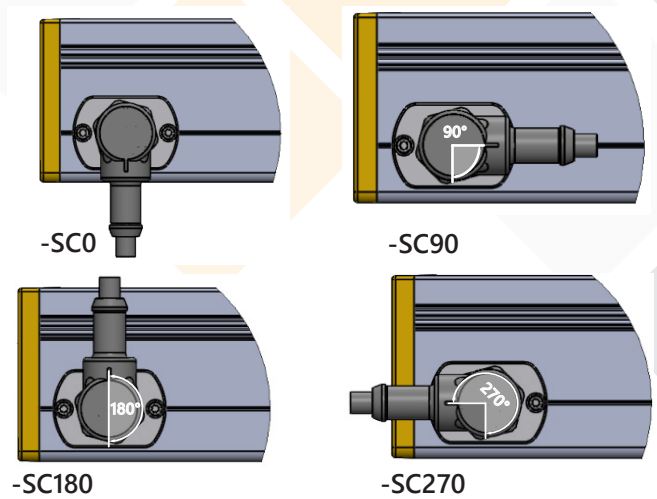
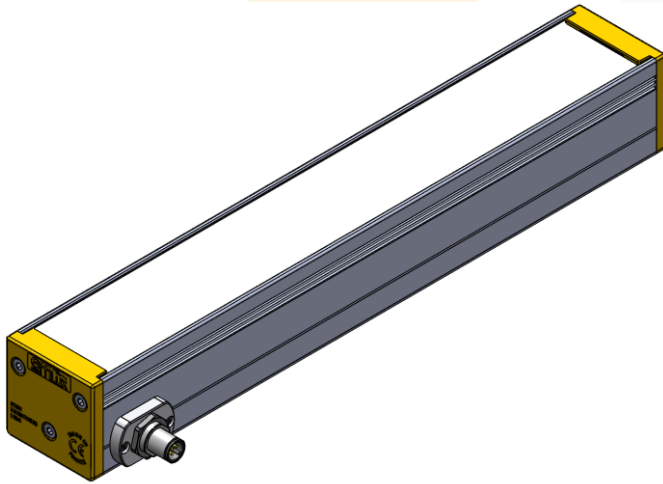

EFFI-FLEX2-XXXX-ZZZ-WW-PP-SCXXX
EFFI-FLEX2-XXXX-ZZZ-WW-PP-SCXXX-1M12P

Connector on the side of the extrusion

XXX= Angle connector orientation (standard 0°: angled cable going to the back of the light)

M12 - 5 pins or M12P - 4 pins. Not available with 2M12P connectors.

Please check the connector according to the light size.

SIDE CABLE GLAND - M12

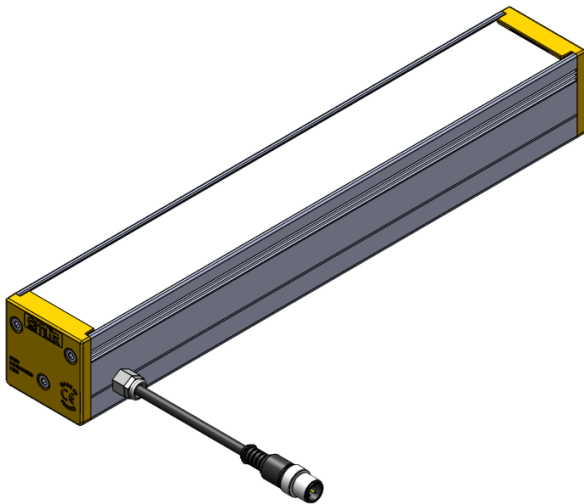

EFFI-FLEX2-XXXX-ZZZ-WW-PP-SCG

Cable gland on the side - Cable length: 500mm +/- 20mm

M12 - 5 pins. Not available with M12P connector.

Please check the connector according to the light size.